

Ten+ Years of Online Research: Results and Reflections



**Curtis J. Bonk,
Indiana University**

<http://php.indiana.edu/~cjbonk>
cjbonk@indiana.edu



Theoretical Perspectives and Principles

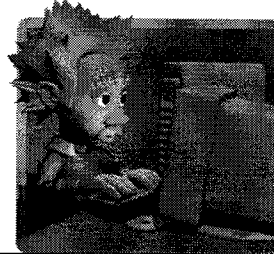

Learner-Centered Learning Principles

From American Psychological Association, 1993

Cognitive and Metacognitive Factors

1. Nature of the learning process
2. Goals of the learning process
3. Construction of knowledge
4. Strategic thinking
5. Thinking about thinking
6. Context of learning

Motivational and Affective Factors

7. Motivational and emotional influences
8. Intrinsic motivation to learn
9. Effects of motivation on effort

Developmental and Social Factors

10. Developmental influences on learning
11. Social influences on learning

Individual Differences

12. Individual differences in learning
13. Learning and diversity
14. Standards and assessment



Constructivistic Teaching Principles (Brooks, 1990)

1. Build on student prior knowledge.
2. Make learning relevant.
3. Give students choice in learning activity.
4. Student autonomy & active learning encouraged
5. Use of raw data sources & interactive materials
6. Encourage student dialogue
7. Seek elaboration on responses and justification
8. Pose contradictions to original hypothesis
9. Ask open-ended questions & allow wait time
10. Encourage reflection on experiences



Sociocultural Ideas (Bonk & Cunningham, 1998)

1. Shared Space and Build Intersubjectivity
2. Social Dialogue on Authentic Problems (mind is in social interactions and extends beyond skin)
3. Mentoring and Teleapprenticeships
4. Scaffolding and Electronic Assistance in ZPD
5. Group Processing and Reflection
6. Collaboration and Negotiation in ZPD
7. Choice and Challenge
8. Community of Learning with Experts & Peers
9. Portfolio Assessment and Feedback
10. Assisted Learning (e.g., task structuring)
11. Reciprocal Teaching & Peer Collaboration



Premise #1: Importance of Social Interaction (Vygotsky, Wertsch, etc.)

- Social interaction develops new patterns of thought and strategic behaviors.



Premise #2. Mind is Distributed in Society

- **Mind is in society—individual-in-social-action; mind extends beyond the skin** (Vygotsky, Wertsch, etc.).



Distributed Intelligence (in a learning community)

- Student higher-order mental functioning has its' roots in social relations. The mind, therefore, is distributed in society, and, extends beyond one's skin. Since knowledge is negotiated by members of a community of practice, the classroom should be organized to guide student learning toward membership in a learning community.

Distributed Intelligence (in a learning community)

- Participation in such a classroom is no longer didactic or transmissive, but a sophisticated instructional conversation.



Distributed Intelligence (in a learning community)

- While technology is vital here, it is but one resource of a learning community; other resources that should also be utilized include: experts, mentors, peers, curriculum/textbooks, teachers, self-reflection, assessment, parents, and the funds of capital within one's local community.

Premise #3. Learning Precedes Development

- **Learning precedes development—so must nudge, prompt, provoke it, rouse it to life, etc.**



Premise #4: Cognitive Apprenticeship

- Learners should be acculturated into an established community of practice. This is done through guided participation, scaffolding, and a gradual transfer of responsibility for the learning from the more experienced partner to the learner.



Guided Learning Model (Rogoff, 1990)

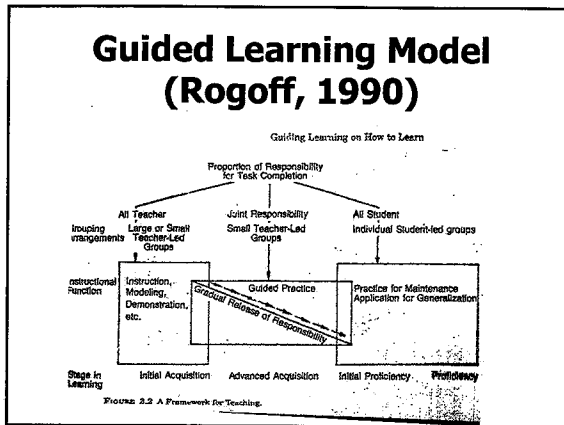

Cognitive Apprenticeship

- Collins, Brown, and Newman (1989) detail six teaching methods in an ideal cognitive apprenticeship; (1) modeling, (2) coaching, (3) scaffolding and fading, (4) articulation, (5) reflection, and (6) exploration.



Tele-apprenticeship

- As a result of advances in technology tools, there are myriad online learning environments that are mediated by experts, peers, mentors, teachers, etc. to help learners and teachers build and share knowledge through access to specialized expertise and information.



Premise #5:

Zone of Proximal Development

A range of tasks too difficult for child to manage alone, but which can be achieved through interaction with another person (adult or more capable peer)

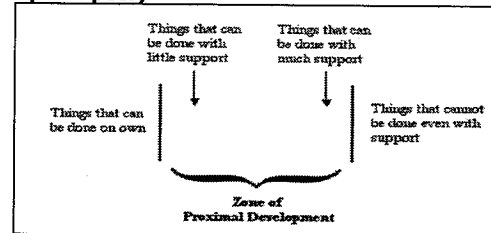

Premise #6: Scaffolding in one's ZPD (Robert Slavin, 1993)

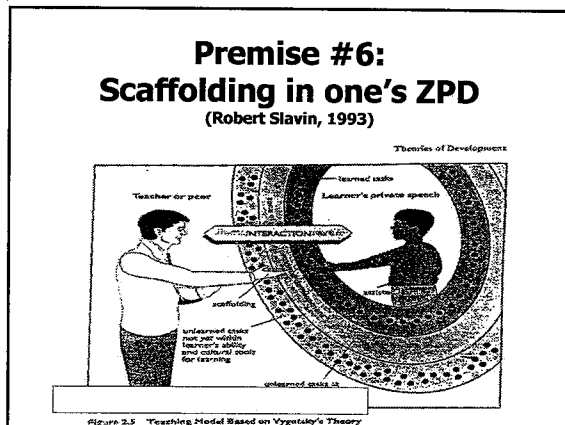

Types of Scaffolding

- Social Acknowledgement
- Questioning
- Direct Instruction
- Modeling/Examples
- Feedback/Praise
- Cognitive Task Structuring
- Cognitive Elaborations/Explanations
- Push to Explore
- Fostering Reflections/Self Awareness
- Encouraging Articulation/Dialogue Prompting
- General Advise/Scaffolding/Suggestions
- Management

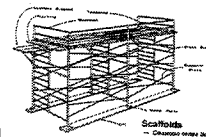

Premise #7: Assisted Learning

- There are a range of techniques for teachers to assist in the learning process (e.g., modeling, coaching, scaffolding and fading, questioning, directly instructing, task structuring, management and feedback, and pushing students to explore, reflect, and articulate ideas).



Premise #8: Learning Resources

- The cultural and intellectual capital within one's teaching and learning environment. Includes peers, textbooks and the curriculum, technology tools, teachers, expert guests, community leaders, tests, self-reflection, etc.



Resources in a Learning Environment

- Teachers
- Peers
- Curriculum/Textbooks
- Technology/Tools
- Experts/Community
- Assessment/Testing
- Self Reflection
- Parents



Premise #9: Authentic Problems

- A learning experience or task which realistically mimics or approximates real world situations. They tend to be more engaging for learners.



Premise #10: Unit of Analysis

- Unit of analysis is the activity or word meaning.

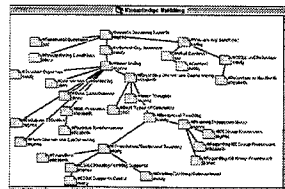

Premise #11: Internalization

- Development moves from external to internal (appears twice).



COGEB highly encourages students to utilize COGEB data to help answer questions about how the environment around them works. Through investigative projects students do, answer, having the importance of finding top-down, analyzing data, drawing conclusions and reporting their results. COGEB Online Investigations are reports of scientific projects conducted by COGEB students that provide the use of COGEB data as projects. By providing your emergency report to the COGEB website you are sharing your valuable findings with the rest of the world and helping the entire planet.

Premise #12: Intersubjectivity

- Refers to a temporary shared collective reality among individuals. Conferencing and collaborative technologies can foster such shared space or situational understanding between learning participants which can help them negotiate meaning, design new knowledge, and perceive multiple problem solving perspectives.



Frameworks and Models

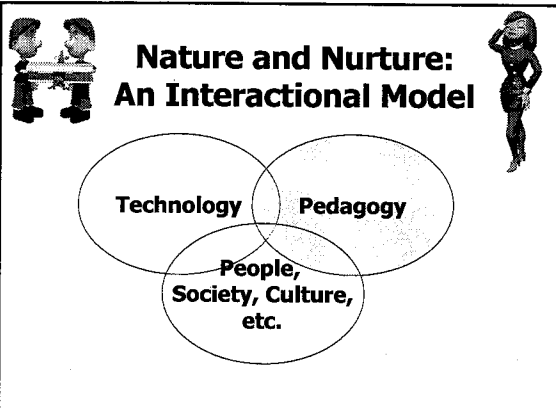
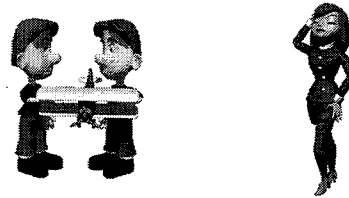



The Web Integration Continuum (Bonk et al., 2000)

- Level 1: Course Marketing/Syllabi via the Web
- Level 2: Web Resource for Student Exploration
- Level 3: Publish Student-Gen Web Resources
- Level 4: Course Resources on the Web
- Level 5: Repurpose Web Resources for Others

- =====
- Level 6: Web Component is Substantive & Graded
 - Level 7: Graded Activities Extend Beyond Class
 - Level 8: Entire Web Course for Resident Students
 - Level 9: Entire Web Course for Offsite Students
 - Level 10: Course within Programmatic Initiative

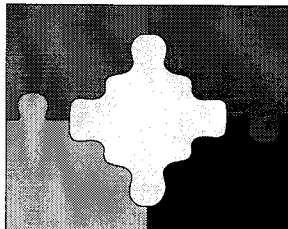
10 Pieces of this Story



- 
- ## 10 Stories for 10+ Years
1. 1993-1994: Peace, dude, hop off the return key, save me some stress."
 2. 1995: What if Vygotsky had lived to 100...
 3. 1996: Do not ride your bike to work.
 4. 1997: Look out for the Russians...
 5. 1998: Do you believe in the power of sharing?
 6. 1999-2000: Do you want to be target practice?
 7. 2001: You were in, but you were never there.
 8. 2002-2005: Who needs a TICKIT?
 9. 2003-2006: Where is Disneyland?
 10. 2004-2006: Data at your fingertips.
- 

Story #1 (1994): "Peace, dude, hop off the return key, save me some stress."

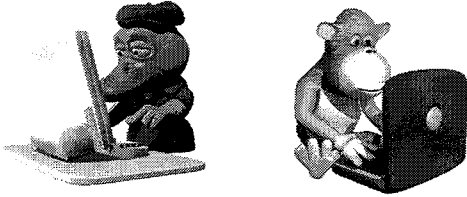

Taxonomy: Level of Collaborative Tool (Bonk, Medury, & Reynolds, 1994)

- Level 0: Stand Alone Tools
- Level 1: E-mail and Delayed Messaging Tools
- Level 2: Remote Access/Delayed Collab Tools
- Level 3: RT Dialoguing and Idea Gen Tools
- Level 4: RT Collaboration (text only)
- Level 5: Cooperative Hypermedia
- Level 6: Tools That Don't Fit Nicely

Web Conferencing Tools

- VaxNOTES
- NiceNet
- WebCrossing
- SITESCAPE Forum
- COW
- FirstClass
- WebCT, Blackboard, Virtual U, etc.



Research on Electronic Cases



- | | |
|--------------------------------|---|
| 1. RT vs. Delayed Collab | 2. Web-Based Conference |
| • Groups Preset by Major | • Grps Formed on Interest |
| • Tchr Generated Cases | • Student Gen. Cases |
| • Local/Univ. Networks | • World Wide Web |
| • Limited Instructor Mentoring | • Extensive Instructor and Peer Mentoring |

Study #1: 1993/1994

(Bonk, Hansen, Grabner, Lazar, and Mirabelli, 1998)

- Two Semester: VAXNotes vs. Connect
- Two Conditions: (1) Real-time vs. (2) Delayed
- Subjects = 65 secondary ed majors
(5 grps: PE, Foreign Language, Social Studies, English, Math)
- Mentors = limited instructor commenting
- Procedures:
 - (1) Respond to 4 cases in small groups
 - (2) Respond to peer comments

Research Questions: Study #1

1. What social interactions occur in real-time & delayed?
2. How code electronic social interaction patterns?
3. How do case size & complexity affect grp processing?
4. Do RT or delayed foster > discuss depth & quality?
5. Do shared experiences stimulate grp intersubjectivity?

Some Findings From Study #1

- Delayed Collab > Elaboration
 - 1,287 words/interaction vs. 266 words/interaction
- RT Collab > Responses
 - 5.1 comments/person/case vs. 3.3 comments/person
- Low off-task behaviors (about 10%)
- Rich data, but hard to code
- Students excited to write & publish ideas
- Minimal q's and feedback
- Interaction inc. over time; common zones
- Some student domination

Study #1. 1993-94

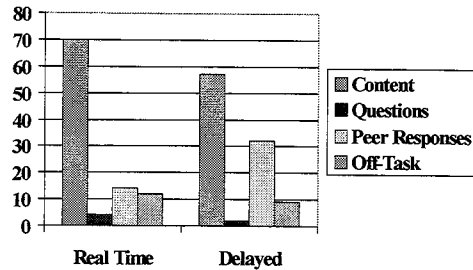

Example of real-time dialogue:

- Come on Jaime!! You're a slacker. Just take a guess. (October 26, 1993, Time: 11:08:57, Ellen Lister, Group 5).
- How might he deal with these students? Well, he might flunk them. He might make them sit in the corner until they can get the problem correct...I don't know. (Um...hello...Jaime where is your valuable insight to these problems?) (October 26, 1993, Time: 11:19:37, Ellen Lister, Grp 5).

Example of Delayed Dialogue:

Joyce's new system offers a wide variety of assessment forms. These different forms complement the diverse learning and test taking abilities of her students. Joyce seems to cover the two goals of classroom assessment with her final exam--to increase learning and increase motivation. Students will increase their learning because they will not just remember information to re[gurgitate] on an exam, but instead they will store these items in their long-term memory and later may be able to make a general transfer. Joyce will increase student motivation because she has deviated from the normal assessment method expected by her students.

Joyce's test will probably be both reliable and valid considering that she implemented three different forms of tests. Joyce's test also might reduce test anxiety. If her students know what to expect on the test (they even wrote the questions) they more than likely will be less anxious on exam day... (January 31, 1994, Time: 19:28, Sarah Fenway, Language Group.)

Larry

- Entertaining,
- Creative and controversial,
- Indirectly intimidating,
- One who set own agenda,
- Very articulate and witty.



Sample of Larry's Comments....

- "Peace, dude, hop off the return key, save me some stress."
- "I am currently preparing my anti-groupwork support group."
- "I've noticed several people writing and saying that they would have done this or that brilliant or intuitive thing. I personally am brilliant or intuitive and I think other could use a little humility. This Karen's made some mistakes, but we all make mistakes, and when (dare I say), we are in her shoes, we should expect to make some of the same ones that confound her."



Story #2 (1995): What if Vygotsky had lived to 100...?

1994-1996 Computer Conferencing and Collaborative Writing (CCCW) Group at Indiana

TEAMWORK

Sample Projects

1. Peer scaffolded support with technology.
2. Critical thinking with tech supports.
3. PBL situations and role play
4. Scaffolded learning from the Arctic.
5. Forms of online e-mail assistance.
6. Bring experts to teach at any time.
7. Online case learning and exam preparation.
8. Alternating class and online activities.
9. Roles in electronic discussions.
10. Structure electronic role play.

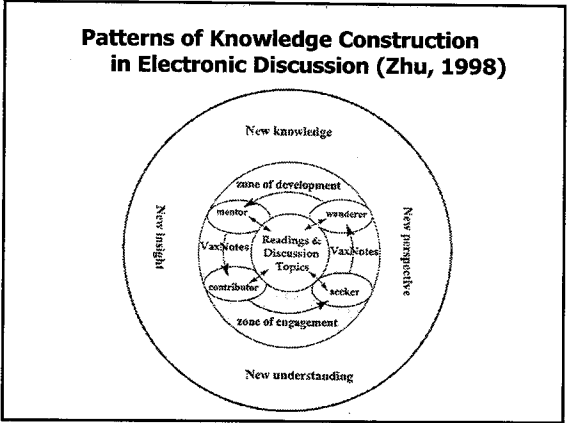

Adventure Learning

Purpose: engage in adventurous study of the global environment. (e.g., Telepresence or virtual fieldtrips, ask an expert forums, cross-classroom collaboration, debate forums, online communities, MayaQuest, the Jason Project)

Adventure Learning Findings (Bonk & Sugar, 1998)

Aspects within Aspects (Cooney, 1998)

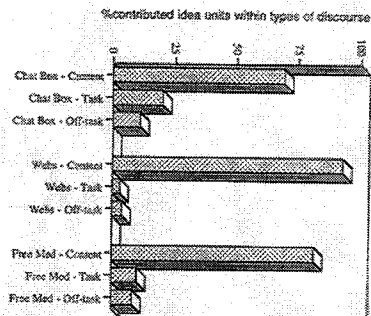

Implications: Build Courses Based on Sociocultural Principles (Bonk, 1998)

Smartweb Activities

- Weekly Chapter Activ
- Starter-Wrapper Disc
- Personal Profiles
- Student Portfolios
- Feedback on Portfolios
- Links Prior Semesters
- Field Reflections
- Field Observ Case Disc
- Café Latte

Sociocultural Link

- Connect to Experience
- Recip Teach & Dialogue
- Build Intersubjectivity
- Dynamic Assessment
- Scaffolding within Zones
- Modeling and Legacy
- Apprentices Learning
- Scaffolded & Authentic
- Shared Knowledge

Story #3 (1996): Do not ride your bike to work.



Conferencing On Web (COW) (1996-2000)

Three Basic Levels:

1. Conference (public or private)
2. Topic (e.g., special education)
3. Conversation (e.g., reading rewards)

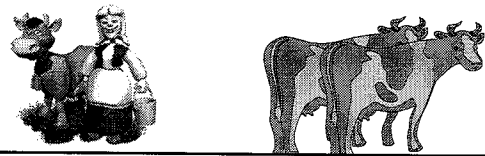

How did people react to COW?

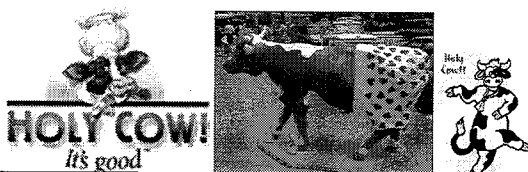

Purpose of COW Project

- Students in field experiences write cases
- Teachers and students from around the world provide electronic mentoring
- Authentic cases and mentoring transform learning environment
- Helps preservice teachers understand the role of technology in education

http://www.indiana.edu/COW/

The Center for Excellence in Education (CEE) at Indiana University



the city web's
COW
CONFERRING
ON THE WEB

W elcome to COW. This system was carefully selected. We hope you enjoy it.

If you would like to tour COW, click the "Enter COW" button and use gear as the login name and cow as the password.

If you have questions or comments, please contact Steve Malhotra at smalhotra@indiana.edu.

About COW **Enter COW** **Lobby**

http://www.indiana.edu/cow/finland_cases_fall98

Finland_Cases_Fall98

You are the instructor for this class (Information Messages) is available.

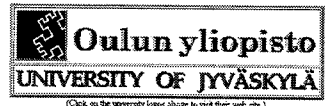

Oulun yliopisto
UNIVERSITY OF JYVASKYLA

(Click on the university logo above to visit their web site.)

We use the Finland Conference! It has been created for you to exchange questions, answers, and ideas with other students, faculty and teachers doing your field experience. You can also return to the conference for lessons, articles, stories and the International Web!

Some of the topics listed below are RESTRICTED to other students, faculty or teachers. Other topics are PUBLIC and anyone may participate. Dr. Dr. Curt D. and Steve Malhotra serve as "the trustees" to this conference, and they can read ALL messages.

View A message board has been created to help you become familiar with the online system and program.

Topics:

Number	New	Topic Name
--------	-----	------------

Indiana Cases Fall98 Microsoft Internet Explorer

http://www.indiana.edu/cow/finland_cases_fall98

Topics:

Number	New	Topic Name
100	1	San Global Problems
102	74	Classroom Management-Demoral
103	65	Classroom Management-Discipline and Behavior Problems
104	8	Classroom Cases, Math-Science
105	13	Classroom Cases, Reading-Writing
106	8	Classroom Cases, Social Studies-Other
110	34	Individuals, Rites (RSE, IC, Gender, Religion, etc.)
111	25	Adaptation to Homeless Students From The
112	7	Homeless-Homelessness and Community Cases
113	74	Profr. Teacher Behavior (e.g., bias, favoritism, etc.)
114	19	Language Problems
115	13	Language Problems & Intelligence
118	31	Legal Problems
120	74	Mathematics
122	39	Mathematics-Instruction-Instruction
123	3	Maths, Sci, and Health (Any Grade, Level)
124	16	Physical Education and Health (Any Grade Level)
125	23	Reading and Assessment (e.g., standardized material)
126	2	Writing and Assessment (e.g., standardized material)
128	11	Secondary Cases-Instruction, English & Art
130	0	Secondary Cases-Health & Science
132	0	Secondary Cases-Health, English & Other
134	30	Technology-Computers and Internet/Net
150	55	Site Cases (Please view the "site" messages)

Finland_Cases_Fall98 Topic 202 Microsoft Internet Explorer

http://www.indiana.edu/cow/finland_cases_fall98/Topic202

Topics Messages is available.

by Maarit Saarekumari (msaarek@...)
Date: Sep. 10 11:58 PM 1998

To read a case, click on one the "conversations" listed below.
To add a case, click on the Start New button.

Recent Conversations for Finland_Cases_Fall98, Topic 202: (CONS=arch)

Number	Total	New	Conversation
5	11	0	MINI-LITTA KOKOUSKOKO - onko se koulun koulun koulun?
2	22	0	Gender and Classroom
6	20	0	PARHAINEN IN THE ELEMENTARY SCHOOL...
9	16	0	TEACHERS... AND... AND... AND...
0	16	0	CHANGES OF CLASS OF THE HOUSE?
3	11	0	THE TEACHERS ARE ALWAYS CRITIC... AND...
1	22	0	TEACHERS AND TEACHERS...
7	18	0	THE... AND... AND... AND... AND...
4	11	0	TEACHERS AND...

Find conversation number: Since days ago

Secondary Ed Cases Fall98 Case 170 Case 13 Hotpage

http://www.indiana.edu/cow/finland_cases_fall98/case170.html

<< Return to Previous Topic <<< ... and new post >>>

Conference: Secondary_Ed_Cases
Topic: 170. Your Own Cases--Secondary
Conversation 13

My student and Cocaine

All posts and replies

1 Author: Name Removed (Username)
Date: Oct. 22 7:05 PM 1997

The first day of my observing I connected with a team. She felt comfortable talking to me and frequently asked during the two class periods I was observing, she is the girl I have in any of my classes. She is helpful, considerate, extremely bright.

I have been back to observe twice since then. Today 10-22-97, when I went to observe today, she was not in class. I asked the teacher if she had been absent the day before, and I asked him if

Problems Solved By COW

- Student isolation in field experiences
- Lack of community/dialogue among teacher education participants
- Disconnectedness between class and field experience
- Limited reflective practices of novice teachers
- Need for appreciation of multiple perspectives

Quantitative Methods

Average results for prior to TITLE (TITLE):

- Participants per semester: 130 (>300)
- Cases per semester: 230 (624)
- Cases per student: 1.75 (same 1.80)
- Average responses per case: 4.5 (3.9)
- Average words per case: 100-140 (198)

Frequent Case Topics

Topic	Number of Cases
Management	312
Motivation	185
Instructional Approaches	178
Individual Differences (special education and gifted)	152
Hot Topics (e.g., teacher burnout, violence in school, corporal punishment, and drugs and alcohol)	83
Development (physical, cognitive, and social/emotional)	70
Behaviorism and Social Learning Theory	57

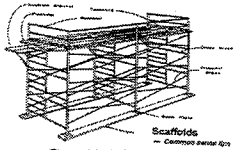

Types of Heavy Scaffolding:

1. Social Acknowledgement
2. Questioning
3. Direct Instruction
4. Modeling/Examples
5. Feedback/Praise
6. Cognitive Task Structuring
7. Cognitive Elaborations/Explanations
8. Push to Explore
9. Fostering Reflection/Self Awareness
10. Encouraging Articulation/Dialogue Prompting
11. General Advice/Scaffolding/Suggestions
12. Management

Bonk, Angeli, Malikowski, & Supplee, 2001



Transcript Results

A. Peer Content Talk

- 31% Social Acknowledgments
- 60% Unsupported Claims and Opinions
- 7% Justified Claims
- 2% Dialogue Extension Q's and Stmts

B. Mentor Scaffolding

- 24% Feedback, Praise, and Social
- 24% General Advice and Suggestions
- 20% Scaffolding and Socratic Questioning
- 16% Providing Examples and Models
- 8% Low Level Questioning
- 8% Direct Instruction & Explanations/Elab

Study #3. Fall, 1997

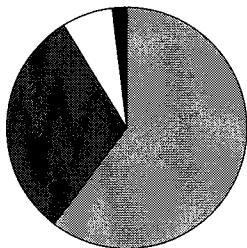

- Unsupported
- Social
- Justified
- Extension

Bonk, Malikowski, Supplee, & Angeli, 1998

Overall Major Findings

- COW enhanced student learning
 - provided a link between classroom and field; connected to textbook concepts
 - encouraged learning about technology
- COW extended student learning
 - students got feedback from multiple sources and outside their community
 - students saw international perspective
- COW transformed student learning
 - students took ownership for learning
 - students co-constructed knowledge base

Qualitative Themes Continued...

- Students were attracted to cases that...
 - had interesting titles
 - were on familiar topics
 - were on controversial topics
 - they had opinions about
- Peer feedback was appreciated but not deep
- Mentor feedback was apprec. & motivating

Study: COW, Spring 1998 (Bonk, Malikowski, Supplee, & Dennen, 2000)

- Two Month Conference (One Condition)
 - 3 discussion areas (IU, Finland, and Cultural Immersions)
- Subjects = 110 students
(80 US and 30 Finnish students)
- Mentors = 2 AIs, 1 supervisor, 4 coop tchrs, 3 conference moderators.
- Videoconferences + Web Conferences

Finnish Cases Were Longer and more Reflective and Often Co-Authored...

Lets consider a math class in an elementary school as an example. Often a teacher teaches the new subject area and after that pupils practice counting those exercises. When a pupil has finished s/he receives extra exercises, or s/he is asked to do some work in other subjects but s/he is not allowed to continue further in the math book. Should the pupil be allowed to continue further on her/his own if s/he wants to? There is a danger that if s/he continues s/he will make more mistakes than if s/he waits until the teacher has taught the next step in the subject area. However, is it dangerous to do mistakes? Do teachers suppose that outside school there is always someone to tell what to do and how to do it in a right way?

Marya Ford Washington states in her summary: "It is painful to consider that a good portion of America's gifted and talented students spend most of their elementary and middle school careers learning to be average. It is even more painful to admit that they usually succeed." The same seems to apply to Finland. How could we solve this problem? Maarit & Maija

Vertical Mentoring Examples

9. Author: Jerry Cochey (Mentor)
Date: Mar. 11 1:46 PM 1998

To shift from teacher centered classrooms to child centered classrooms and learning takes time, patience and a commitment to the idea that students are responsible for their own learning. Even in this age of enlightenment(?), we think that a quiet, teacher controlled classroom shows learning, while research shows that active, talking, sharing of learning experiences with peers is more productive. Be patient, it takes a long time to have students change to being responsible for their own.

Horizontal Finnish Mentoring

12. Author: Leena Date: Mar. 30 11:52 AM 1998

This case is something I feel very close to. I have been trying struggle with finding ways to be a teacher in a new way, trying to think everything from the students' perspective, to challenge my own old traditions of teaching and try to seek ways which the I could find ways of studying things together with the students. What really puzzles me is that these different "projects" have had such extremely different lives.....What I really don't know yet is how to be a proper supporter of these processes for students... - Leena

Justified Statement (Finnish)

3. Author: Kirsi

Date: Mar. 6 8:11 AM 1998

Why not let the student study math further by himself and the teacher could help him whenever the teacher has time. At least some of the math study books are so designed that one page has examples that teach you how to solve the problem and then on the next page there are exercises. I personally hate being said 'wait' since when I'm interested in something I want to go on and learn more and not wait. This way I think the child learns to be responsible of his own learning. If I quote dear mr Vygotsky here again, the teacher should be sensitive to see where the child's proximate zone of development is and to help him 'over' it. The teacher's task is not to try to keep the child on the level he has reached but to help him learn more if he is interested...

Unjustified Statements (US)

24. Author: Katherine

Date: Apr. 27 3:12 AM 1998

I agree with you that technology is definitely taking a large part in the classroom and will more so in the future with all the technological advances that will be to come but I don't believe that it could actually take over the role of a teacher...but in my opinion will never take over the role of a teacher.

25. Author: Jason

Date: Apr. 28 1:47 PM 1998

I feel technology will never over take the role of the teacher...I feel however, this is just help us teachers out and be just another way for us to explain new work to the children. No matter how advanced technology gets it will never be able to...

26. Author: Daniel

Date: Apr. 30 0:11 AM 1998

I believe that the role of the teacher is being changed by computers, but the computer will never totally replace the teacher... I believe that the computers will eventually make teaching easier for us and that most of the children's work will be done on computers. But I believe that there will always be the need for the teacher.

Indicators for the Quality of Students' Dialogue (Angeli, Valanides, & Bonk, 2003)

ID	Indicators	Examples
1	Social acknowledgement/ Sharing/Feedback	Hello, good to hear from you...I agree, good point, great idea
2	Unsupported statements (advice)	I think you should try this....This is what I would do...
3	Questioning for clarification and extend dialogue	Could you give us more info? ...explain what you mean by...?
4	Critical thinking, Reasoned thinking-judgment	I disagree with X, because in class we discussed....I see the following disadvantages to this approach....

TITLE

Fair Witness: Dr. Curt Beak (email: drbeak@stetson.edu)

Welcome to "The Interdisciplinary Teacher Learning Exchange" (TITLE). Here, you can discuss problems seen in schools, write case situations, ask for feedback, or joke with peers in the cafes.

Topics:

Number	Rev	Topic Name
100	59	The Interpersonal Cafe
300	69	Class Management--General & Class Planning
310	166	Class Management--Discipline & Behavior Tech
320	53	Class Management--Real Difficult Situations/Plans
380	99	Classroom--Instructional Tech, Delivery, a Question on Gift Students
370	28	Classroom--Tech, Games, or Personal Journals, etc.
380	60	Classroom--Instructional/General Ed. Includes DISTED
400	68	Classroom--General Feedback and Comments
420	60	Classroom--Peer Review/Feedback (Good, Excellent, etc.)
430	69	Classroom--General Feedback, Questions, Forum, Polls
500	11	Classroom--General Feedback & Culture in the Classroom
520	33	Classroom--General Feedback, Planning and Learning
530	16	Culture--Influence of Religion in Education
530	7	Culture--Influence of Religion--General American Background

Caseweb Visions

- Intros, Expert Commentaries, Reviews
- Expanded and Shrunken Case Views
- Hyperlink Options
- Conceptual Labels--chapters, themes, ideas
- Role Taking Options
- Mentoring Scaffolds/Questions
- Forced Counterpoints
- Sample Mentor and Peer Feedback
- Case Comparison Statistics

Story #4 (1997): Look out for the Russians...



Spring of '97 (FirstClass) Content Analysis of Online Discussion in Ed Psych (Hara, Bonk, & Angeli, 2001, Instructional Science)

- Purpose and Questions of this Study**
- To understand how graduate students interact online?
 - What are inter patterns with starter-wrapper roles?
 - What is role of instructor in weekly interactions?
 - How extensive is social, cog, metacog commenting?
 - How in-depth would online discussions get?
 - And can conferencing deepen class discussions?

Dimensions of Learning Process (Henri, 1992)

1. **Participation** (rate, timing, duration of messages)
2. **Interactivity** (explicit interaction, implicit interaction, & independent comment)
3. **Social Events** (stmts unrelated to content)
4. **Cognitive Events** (e.g., clarifications, inferencing, judgment, and strategies)
5. **Metacognitive Events** (e.g., both metacognitive knowledge—person, and task, and strategy and well as metacognitive skill—evaluation, planning, regulation, and self-awareness)

Graduate Course Findings

• Participation

- + Most participated once/week
- + Student-centered & depend on starter
- + Posts more interactive over time
- + Lengthy & Cognitively Deep
 - Ave post: 300 words & over 18 sentences
 - From 33 words to over 1000 words
- Some just satisfied course requirements

Findings Continued

(see Henri, 1992)

- **Social** (in 26.7% of units coded)
 - social cues decreased as semester progressed
 - messages gradually became less formal
 - became more embedded within statement
- **Cognitive** (in 81.7% of units)
 - More inferences & judgments than elem clarifications and in-depth clarifications
 - Cog Deep: 33% surface; 55% deep; 12 both
- **Metacognitive** (in 56% of units)
 - More reflections on exper & self-awareness
 - Some planning, eval, & regulation & self q'ing

Cognitive Skills Displayed in Online Conferencing

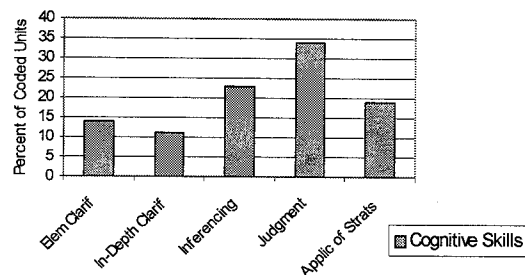

Metacognitive Skills Displayed in Online Conferencing

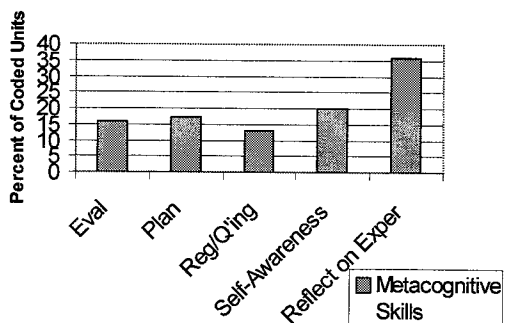

Surface vs. Deep Posts

(Henri, 1992)

Surface Processing

- making judgments without justification,
- stating that one shares ideas or opinions already stated,
- repeating what has been said
- asking irrelevant questions
- i.e., fragmented, narrow, and somewhat trite.

In-depth Processing

- linked facts and ideas,
- offered new elements of information,
- discussed advantages and disadvantages of a situation,
- made judgments that were supported by examples and/or justification.
- i.e., more integrated, weighty, and refreshing.

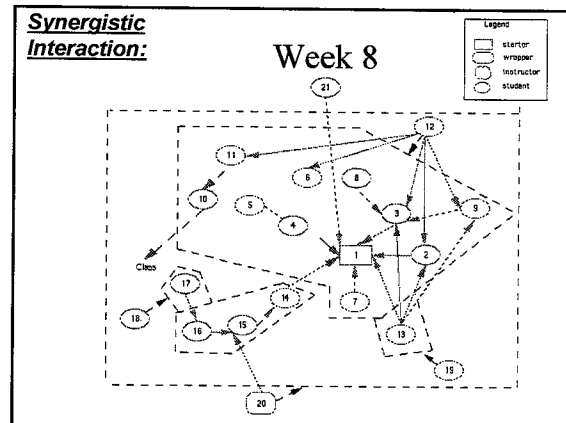
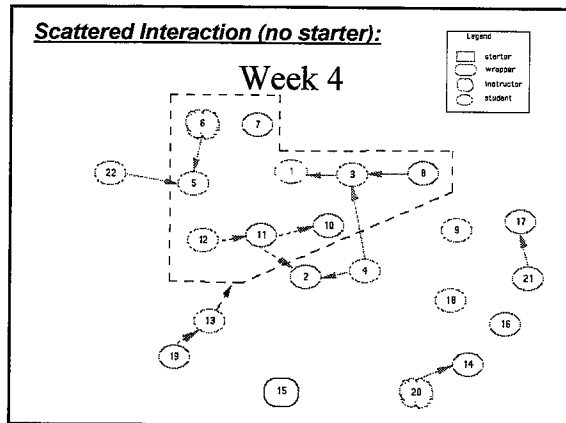
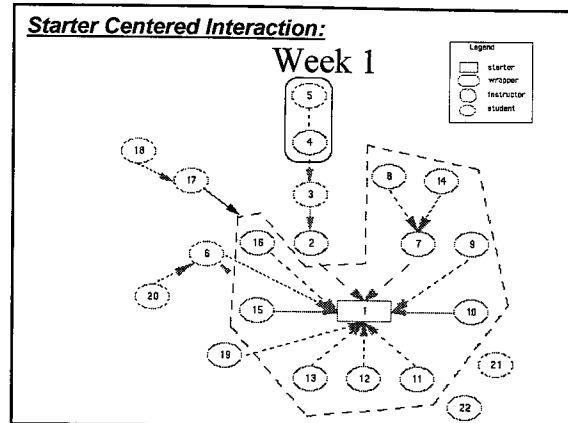
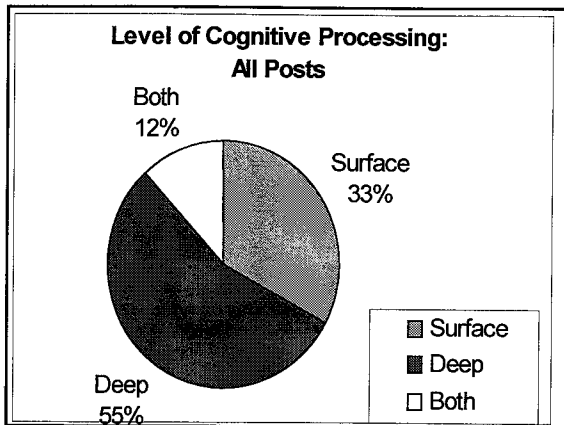

- ## Recommendations
- **Structure online discussions**
 - e.g., get them to use subject line better.
 - **When done, have them print out transcripts!**
 - Can take the class with them when done!
 - **Realize that diff conferencing software and features serve diff instructional purposes**

Story #5 (1999): Do you believe in the power of sharing?

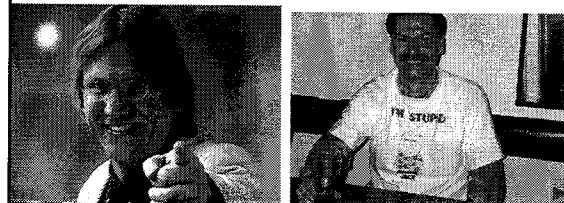

1999 Study of the World Lecture Hall Matrix of Web Interactions (Cummings, Bonk, & Jacobs, 2002)

Instructor to Student: syllabus, notes, feedback
to Instructor: Course resources, syllabi, notes
to Practitioner: Tutorials, articles, listservs
Student to Student: Intros, sample work, debates
to Instructor: Voting, tests, papers, evals.
to Practitioner: Web links, resumes
Practitioner to Student: Internships, jobs, fieldtrips
to Instructor: Opinion surveys, fdbk, listservs
to Practitioner: Forums, listservs

Table 2
Percent of online syllabi with different options for communication flow among instructors, students, and practitioners/experts

	To students	To instructors	To practitioners/experts
From instructor	Assignment schedule (70%) Class roster (10%) Lecture notes/PowerPoint slides (43%) Web links (70%) Instructor profiles (70%)	Online syllabi (100%) Web forums or discussions on course material (4%) Lecture notes/activities (43%)	Online tutorials (3%) General information (1%)
From students	Post or publish current student work (14%) Within-course discussions or electronic conferences (65%) Outside of course discussions (5%) Personal profiles (10%)	Journal reflections (6%) Online quizzes/tests (38%) Reflective electronic minute papers (0%) Session evaluations (3%) Instructor email feedback (84%)	Web links (13%) Resumes on the Web (0%)
From practitioners/experts	Jobs (0%) Virtual field trips (5%)	Course feedback (0%)	Virtual professional development communities (0%)

Story #6 (2000): Do you want to be target practice?

Bonk, C. J., & Wisher, R. A. (2000). *Applying collaborative and e-learning tools to military distance learning: A research framework*. (Technical Report #1107). Alexandria, VA: U.S. Army Research Institute for the Behavioral and Social Sciences.

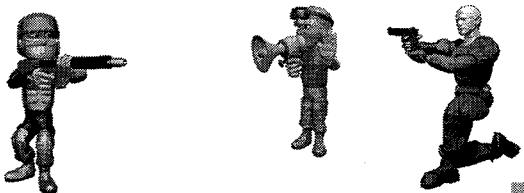

Online Officer Training Program (2000-2003)

- Evaluated social interaction, problem solving, online mentoring, and social interaction environment of Army officer training program; focus on instructional design, blended learning.

Online Officer Training Program Team

- Dr. Robert Wisher, DOD and ARI
- Dr. Tatana Olson, was at SRI/Purdue, now at Navy as Aviation Experimental Psychologist, Pensacola (wants to be first female fighter pilot)
- Dr. Kara Orvis, was at ARI, Optima, Boston.
- Dr. Ji-Yeon Lee, University of South Carolina (now at Inha University in Korea)
- me

Orvis, K. L., Wisher, R. A., Bonk, C. J., & Olson, T. (2002). Communication patterns during synchronous Web-based military training in problem solving. *Computers in Human Behavior*, 18(6), 783-795.

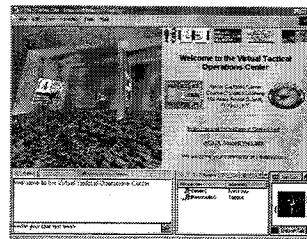

Study #1: Synchronous Chat Analysis
(explored learner online problem solving)

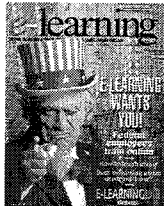
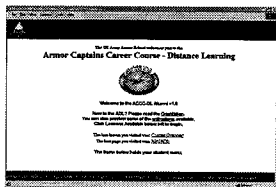

Orvis, K. L., Wisher, R. A., Bonk, C. J., & Olson, T. (2002). Problem-solving exercises in military training: Communication patterns during synchronous Web-based instructions. *Computers in Human Behavior*.

Three Phases of AC3-DL

- I. Asynchronous Phase:** 240 hours of instruction or 1 year to complete; must score 70% or better on each gate exam
- II. Synchronous Phase:** 60 hours of asynchronous and 120 hours of synchronous; Virtual Tactical Operations Center (VTOC) (7 rooms; 15 people/extension (chat, avatars, audio conferencing)
- III. Residential Phase:** 120 hours of training in 2 weeks at Fort Knox

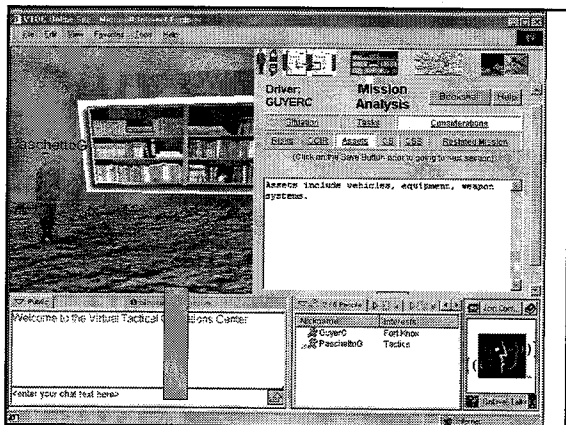

Previously Reported Results

Sanders & Burnside (2001); Sanders & Guyer (2001)

- Completed coursework in less time than correspondence course.
- Positive attitudes
- Covered add'l content not in correspondence
- More likely to make decisions
- Develop greater sense of team identity
- Greater planfulness, confidence, tactical proficiency, and leadership skills.
- Problems encountered: time, drill time conflicts, tech problems, family responsibilities, no compensation



Study #1. Overall frequency of social, mechanical, and on-task interactions across chat categories (6,601 chats).
(Note: conducted focus groups, interviews, q'ers, chat transcript analyses, document analyses)

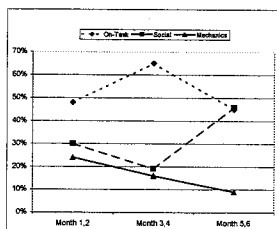

Overall frequency of interactions across chat categories (6,601 chats).

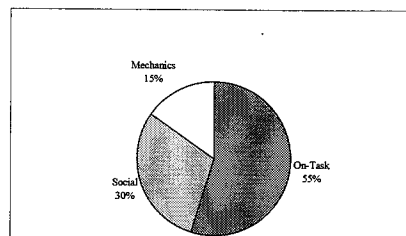

On-Task Problem Solving Mayer & Wittrock (1996); Sternberg (1997)

- "Terrain does not allow for effective maneuver of your element"
- "Harder to detect a liquid agent in rain"
- "Rain can also degrade optics on weapon systems"
- Remember in the BDE OPORD-the BDE CMDR wants this to occur at about this time"

Social Interactions

- "Kids are great we made breakfast for Mom (wife)"
- "Did you go out for a run last night?"
- "Tell her I said happy mothers day"
- "3 miles in 24 mins all hills"
- "If God had meant for us to run, he wouldn't have given us tanks"



Study #2 Reflections on Blended

Bonk, C. J., Olson, T., Wisher, R. A., & Orvis, K. L. (2002). Learning from focus groups: An examination of blended learning. *Journal of Distance Education, 17*(3), 97-118.

- Some Keys: feedback, smaller modules, need instructor facilitation, use basic tech, move from async to sync, better orientation sessions
- Enjoyed the course, excellent technologies
- Favored sync over asynchronous
- All noted ways to address high attrition
- Perceived training transfer, active learning
- Learned to work as a team
- High individual and collective efficacy

Bonk, C. J., Olson, T., Wisher, R. A., & Orvis, K. L. (2002). *Reflections on blended learning: The Armor Captains Career Course*. (Research Note #2002-13). Alexandria, VA: U.S. Army Research Institute for the Behavioral and Social Sciences.

Follow-up: Massive Multiplayer Online Gaming (MMOG) (2003-2005)

- Exploring the educational and training potential of massive multiplayer online games and mapping out a research agenda in this area for the Advanced Distributed Learning Lab within the Department of Defense.

Massive Multiplayer Online Gaming (MMOG) Team

1. Dr. Vanessa Dennen, Florida State
2. me
3. With help from Dr. Robert (Bob) Wisher

Publications: Massive Multiplayer Online Gaming (MMOG)

1. Bonk, C. J., & Dennen, V. P. (2005). *Massive multiplayer online gaming: A research framework for military education and training*. (Technical Report # 2005-1). Washington, DC: U.S. Department of Defense (DUSD/R): Advanced Distributed Learning (ADL) Initiative.

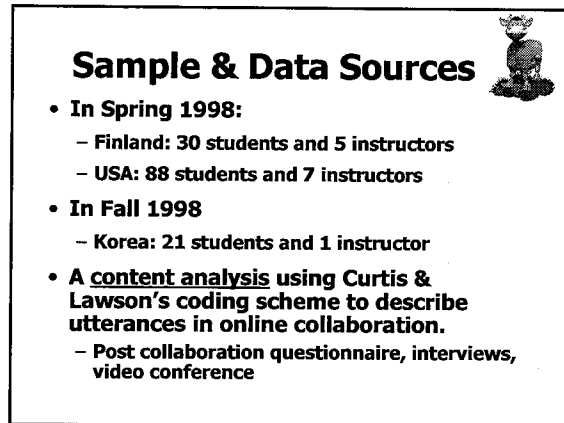
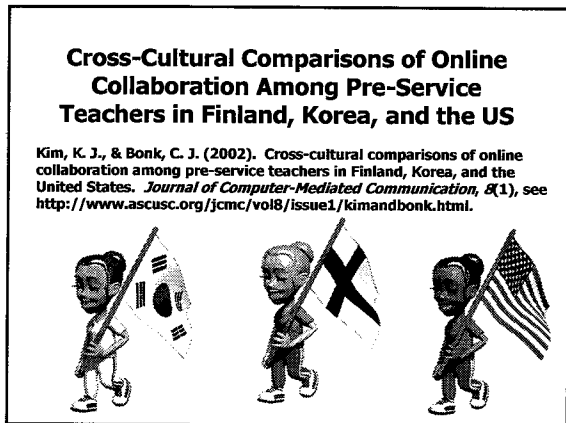
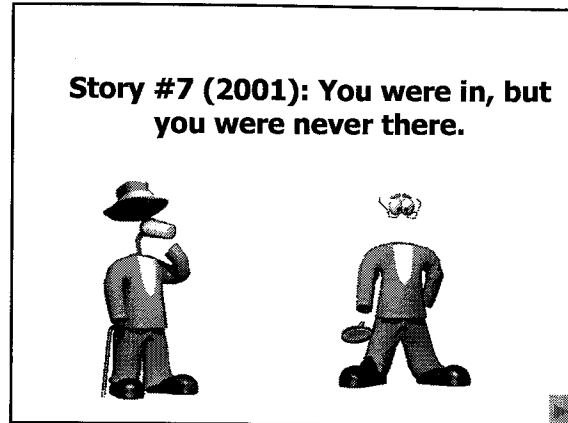
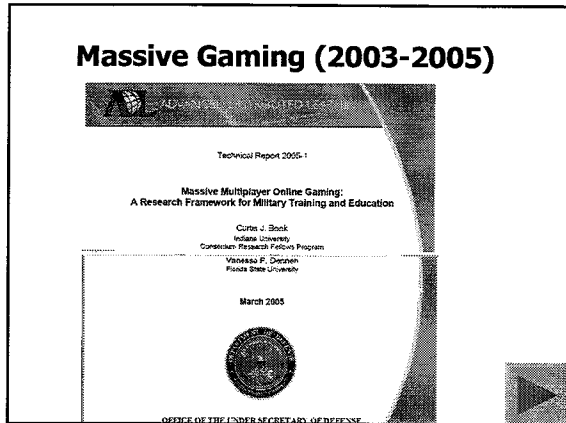

Behavior Categories	Codes	Description
Planning	GS	Group Skills
	OW	Organizing Work
	IA	Initiating Activities
Contributing	HeG	Help Giving
	FBG	Feedback Giving
	RI	Exchanging Resources and Information
	SK	Sharing Knowledge
	CH	Challenging Others
Seeking Input	EX	Explaining or Elaborating
	HcS	Helping Seeking
	FBS	Feedback Seeking
Reflection/ Monitoring	Ef	Advocating Efforts
	ME	Monitoring Efforts
Social Interaction	RM	Reflection on Medium
	SI	Social Interaction

Online Collaboration Behaviors by Categories

Behavior Categories	Conferences (%)		
	Finland	U.S.	Average
Planning	0.0	0.0	0.0
Contributing	80.8	76.6	78.7
Seeking Input	12.7	21.0	16.8
Reflection/ Monitoring	6.1	2.2	4.2
Social Interaction	0.4	0.2	0.3
Total	100.0	100.0	100.0

Online Collaboration Analysis (Korea)

Behavior Categories		Korean	
		Code totals	Code percent
Planning	GS	0	0
	OW	0.0	0.0
	IA	0	0
Contributing	HeG	2	2
	FBG	1.3	1.3
	RI	44	44
	SK	28.4	28.4
	CH	2	2
Seeking Input	EX	1.3	1.3
	HeS	1	1
	FBS	0.6	0.6
	RT	36	36
Reflection/Monitoring	ME	3	3
	RM	1.9	1.9
Social Interaction	SI	15	9.7
Total		155	100.0

← Sharing Knowledge

← Advocating efforts

← Social Interaction

Findings from the Quantitative Analysis

- Low participation rate of instructors across all the groups.
 - A majority of utterances fell into the "contributing" category.
 - Cross-cultural differences in "Seeking Input," "Reflection/ Monitoring," and "Social Interaction" behaviors.
 - Differences in the intercultural participation levels across cultures.

Differences in Reflection Behaviors (monitoring effects)

- A Finnish case on student motivation (ME)

"As a result of this discussion so far, we have made some conclusions dealing with students' motivation to learn. We agree that it is impossible to motivate students deliberately. There is not any specific act that can be used to increase students' motivation. According to McCombs, almost everything that teachers do in the classroom has a motivational influence on students ... Intrinsic motivation and self-regulation strategies are also important and these can be supported by successful external supports...."

Differences in Feedback Seeking & Giving

- A U.S. case on disciplinary problems (FBS)

"One day I come into teach the class and one of the twenty students is very quiet. He seemed alright at the time of teaching, but towards the end he just starts crying for no reason... The questions that were raised in my head were: 1. How involved should I get?, 2. Should I call the family and tell them what happened?, 3. Should I tell the other teachers and see what we all can do?"

Differences in Social Interaction Behaviors

- Social Interactions Among Korean students

- Well, like a cup of coffee, may this new thing be relaxing (I am praying now). It must be the beginning, so I am happy now. I wonder whether someone would reply to me. I am a little bit nervous 'cause I am not so familiar with Web conferencing.

- Sister Sunny, take care of yourself, and I hope your health will be good soon. I'm not accustomed to Web conference, either, but it is a good chance to participate. Please, cheer up!

- Thank you for your interest in my health, but I'm all right now. Just before, my long message to you has gone by my slight mistake, so I am sad (crying). And, sorry for my late reply to you.

Communication Styles & Culture

- Low context communication
 - Focuses on explicit verbal message
 - U.S. Finland, and most of the Western cultures
- High context communication
 - emphasizes how intention or meaning is conveyed through the context (e.g., social roles, positions, etc.)
 - Korea and most of the Asian cultures
- Importance of social interaction in the high context communication culture

Findings from the Qualitative Analysis

- U.S. students more action-oriented and pragmatic in seeking results or giving solutions.
- Finnish students were more group focused as well as reflective and theoretically driven.
- Korean students were more socially and contextually driven.

Implications

- Instructors have a key role in facilitating effective cross-cultural communication (e.g. social interaction activities for students from high context cultures).
- Instructional designers and software developers need to build learning tools that address learner needs from different cultures (usability tests in different cultures).
- Online learners need prior examples or case transcripts highlighting cultural differences in communication styles.

Story #8 (2002-2005): Who needs a ticket?

The Pedagogical TICKIT: Teacher Institute for Curriculum Knowledge about the Integration of Technology (1998-2003)

Curt Bonk

Lee Ehman

Emily Hixon

Lisa Yamagata-Lynch

John Keller

Indiana University



TICKIT

(1998 to 2003 and to present)

- Five year investigation of the implementation of the *Teacher Institute for Curriculum Knowledge about the Integration of Technology* which annually trains 25 teachers from 5 rural Indiana schools; exploring long-term impact of inservice technology integration program.

TICKIT Team

1. Dr. Lee Ehman, IU, C&I Dept.
2. Dr. John Keller, IUPUI
3. Dr. Emily Hixon, IU Northwest
4. Dr. Lisa Yamagata Lynch, Univ of Northern Illinois
5. Timothy Hew, IU, IST Dept.
6. me

TICKIT Program Features

- Teachers in rural schools
- Inservice teacher education
- Cohorts of 4-6 teachers per school
- Six hours of graduate credit
- Blended model (e.g. on-line and site-based interactions)
- Action research
- Academic Year Duration





TICKIT Goals



- Knowledge, skill, & confidence
- Thoughtful integration of technology
- Leadership cadres in schools
- Link schools and university
- Help schools capitalize on their technology investments

TICKIT Teachers



Goal Statement



“Obviously, I’m technologically in the Dark Ages. My students are so computer savvy that I feel I must at least attempt to catch up with them.” – Debbie White, North Gibson, summer 2002



North Gibson School Corporation

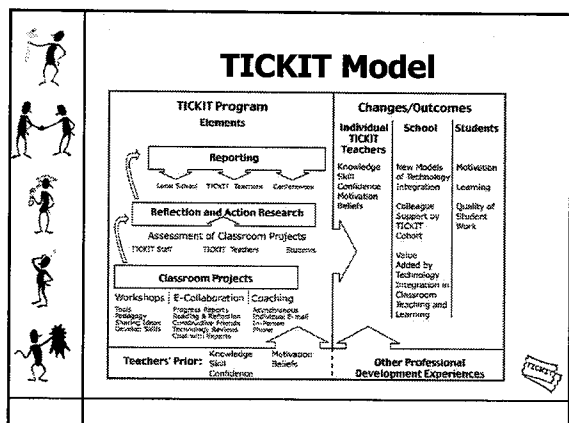

Online Interaction

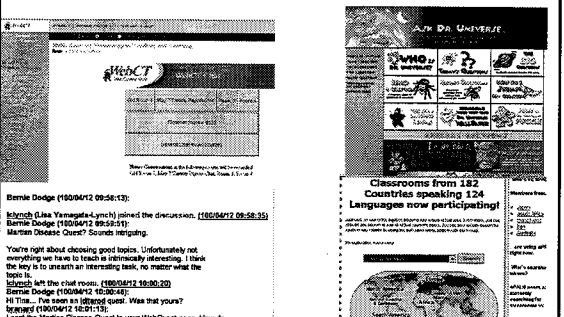

The screenshot shows a discussion forum interface with a list of messages and a chat window. The messages include:

- Bernie Dodge (1800412 09:58:13): [unclear]
- ibrahim (Lisa Venagides4-jmch) joined the discussion. (1800412 09:58:35)
- Bernie Dodge (1800412 09:58:51)
- Marian Disease Quest? Sounds interesting.
- You're right about choosing good topics. Unfortunately not everything we have to teach is intrinsically interesting. I think the key is to search an interesting task, no matter what the topic is.
- ibrahim left the chat room. (1800412 10:00:20)
- Bernie Dodge (1800412 10:00:44):
- Hi Tim... I've seen an [interesting](#) cover. Was that yours?
- ibrahim (1800412 10:01:13):
- I see the Marian Disease Quest to your 1985 Quest page. How do

Typical TICKIT Training and Projects

- **Web:** Web quests, Web search, Web edit/pub. – Includes class, department, or school website.
- **Write:** Electronic newsletters, book reviews.
- **Tools:** Photoshop, Inspiration, PowerPoint.
- **Telecom:** e-mail with foreign key pals.
- **Computer conferencing:** Nicenet.org.
- **Digitizing:** using camera, scanning, digitizing.
- **Videoconferencing:** connecting classes.
- **Web Course:** HighWired.com, MyClass.net, Lightspan.com, eBoard.com



Project type	Number of projects (132)
Webquest	64
Electronic newsletters	1
Web editing & publishing	13
Online conferencing, collab, and discussion (includes email and phone)	10
Virtual tours	1
Computer apps (Excel, PP, Word, Internet)	38
Book review	2
Brochure construction	1
Electronic portfolio	2





Example Projects

Turkey Run Amusement Park





Links to Student's Web P.











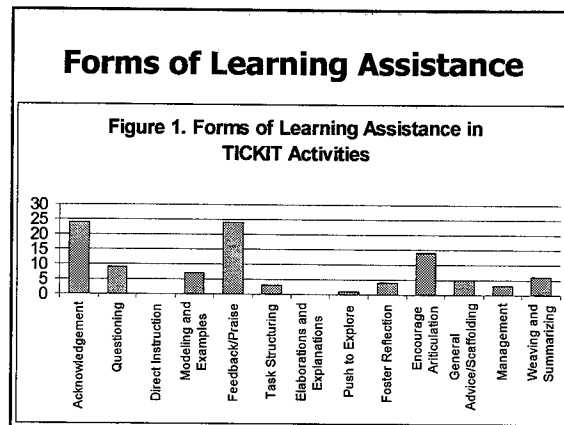

Critical Friend Post Example

"Beverly: Before I forget, I want to thank you again for your invaluable help at the ICE conference. I get used to using a particular piece of equipment or program, and it's hard for me to adapt quickly. You saved the day. One thing I have learned from using technology is that we need to depend upon each other for support. We are all in this boat together."

Findings: Summary

- Feedback, praise, social interaction most frequent
- Critical friends provide peer support, help, social
- Reading reactions & debates more content focus
- Critical friend postings perceived more beneficial
- Reading reactions & debates "just another task"
- Justification: 77% claims unsupported; 20% referenced classroom & other experience
- Depth: ~80% surface level
- Off Task: 7% total; most in critical friend activity



Research Question: Study #2

Do teachers who have been through the TICKIT program differ from teachers who have not on dimensions of computer integration?

